

LEVELING FEET

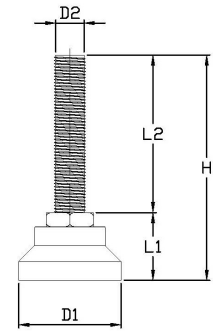

Heavy duty aluminum base leveling feet L series

Application: Clean room equipment, aluminum extrusion equipment, high-load mechanical equipment



Unit: mm

Item No.	Bolt Material	Base Material	D1	L1	D2	L2	H	Load capacity (Kg)	
L6016080	Zinc plated (SS41)	Aluminum	65	43	M16 X P2.0	80	123	1500	
L6016100						100	143		
L6016130						130	173		
L6016150						150	193		
L6016180						180	223		
L6016200						200	243		
L6016250						250	293		
L6020080						M20 X P2.5	80		123
L6020100				100	143				
L6020130				130	173				
L6020150				150	193				
L6020180				180	223				
L6020200				200	243				
L6024100				M24 X P3.0	100		148	3000	
L6024150					150		198		
L6030100					M30 X P3.5	100	148		
L6030150	150	198							
L6036100	M36 X P4.0	100	148	4000					
L605100	46	5/8"-11WT	100	146	1500				
L605150			150	196					
L606100	44	3/4"-10WT	100	144	2000				
L606150			150	194					

Heavy duty aluminum base leveling feet L series

Application: Clean room equipment, aluminum extrusion equipment, high-load mechanical equipment

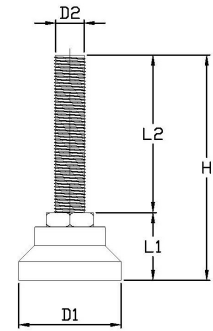

Unit: mm

Item No.	Bolt Material	Base Material	D1	L1	D2	L2	H	Load capacity (Kg)	
L9016080	Zinc plated (SS41)	Aluminum	90	43	M16 X P2.0	80	123	1500	
L9016100						100	143		
L9016130						130	173		
L9016150						150	193		
L9016180						180	223		
L9016200						200	243		
L9016250						250	293		
L9020080						80	123		2000
L9020100				100	143				
L9020130				130	173				
L9020150				150	193				
L9020180				180	223				
L9020200				200	243				
L9024100				48	M24 X P3.0	100	148	3000	
L9024150						150	198		
L9030100						M30 X P3.5	100		148
L9030150			150	198					
L9036100			M36 X P4.0	100	148	4500			
L905100				5/8"---11WT	100	146	1500		
L905150			150		196				
L906100	45	3/4"---10WT	100	145	2000				
L906150			150	195					
L12020080	120	43	M20 X P2.5	80	123	2000			
L12020100				100	143				
L12020130				130	173				
L12020150				150	193				
L12020180				180	223				
L12020200				200	243				
L12024100				48	M24 X P3.0		100	148	3000
L12024150							150	198	
L12030100		M30 X P3.5	100			148			
L12030150			150			198			
L12036100		M36 X P4.0	100	148	4500				
L1206100			3/4"---10WT	100	145	2000			
L1206150		150		195					

Heavy duty aluminum base leveling feet LS series

Application: Clean room equipment, aluminum extrusion equipment, high-load mechanical equipment

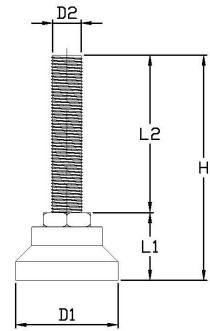

Unit: mm

Item No.	Bolt Material	Base Material	D1	L1	D2	L2	H	Load capacity (Kg)		
LS6016080	Stainless steel (SUS304)	Aluminum	65	43	M16 X P2.0	80	123	1500		
LS6016100						100	143			
LS6016130						130	173			
LS6016150						150	193			
LS6016180						180	223			
LS6016200						200	243			
LS6020080						M20 X P2.5	80		123	2000
LS6020100							100		143	
LS6020130				130	173					
LS6020150				150	193					
LS6020180				180	223					
LS6020200				200	243					
LS6024100				48	M24 X P3.0	100	148	3000		
LS6024150						150	198			
LS6030100	M30 X P3.5	100	148							
LS6030150		150	198							

Heavy duty aluminum base leveling feet LS series

Application: Clean room equipment, aluminum extrusion equipment, high-load mechanical equipment

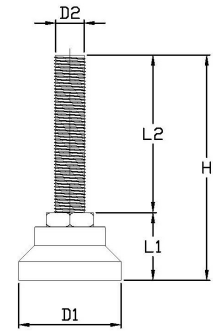

Unit: mm

Item No.	Bolt Material	Base Material	D1	L1	D2	L2	H	Load capacity (Kg)
LS9016080	Stainless steel (SUS304)	Aluminum	90	43	M16 X P2.0	80	123	1500
LS9016100						100	143	
LS9016130						130	173	
LS9016150						150	193	
LS9016180						180	223	
LS9016200						200	243	
LS9020080					M20 X P2.5	80	123	2000
LS9020100						100	143	
LS9020130						130	173	
LS9020150						150	193	
LS9020180			180	223				
LS9020200			200	243				
LS9024100			48	M24 X P3.0	100	148	3000	
LS9024150					150	198		
LS9030100			M30 X P3.5	100	148	3000		
LS9030150				150	198			
LS12020080			120	43	M20 X P2.5	80	123	2000
LS12020100						100	143	
LS12020130						130	173	
LS12020150						150	193	
LS12020180	180	223						
LS12020200	200	243						
LS12024100	48	M24 X P3.0			100	148	3000	
LS12024150					150	198		
LS12030100	M30 X P3.5	100			148	3000		
LS12030150		150			198			

Heavy duty aluminum base leveling feet LR series

Application: Clean room equipment, aluminum extrusion equipment, high-load mechanical equipment

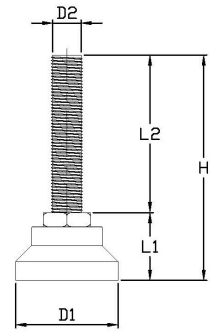
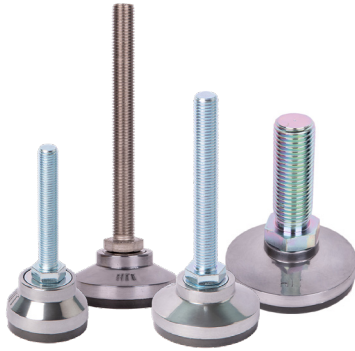

Unit: mm

Item No.	Bolt Material	Base Material	D1	L1	D2	L2	H	Load capacity (Kg)	
L6016080R	Zinc plated (SS41)	Aluminum alloy with rubber pad	65	51	M16 X P2.0	80	131	500	
L6016100R						100	151		
L6016130R						130	181		
L6016150R						150	201		
L6016180R						180	231		
L6016200R						200	251		
L6016250R						250	301		
L6020080R						M20 X P2.5	80		131
L6020100R				100	151				
L6020130R				130	181				
L6020150R				150	201				
L6020180R				180	231				
L6020200R				200	251				
L6024100R				M24 X P3.0	100		156	800	
L6024150R					150		206		
L6030100R					M30 X P3.5	100	156		
L6030150R	150	206							
L6036100R	M36 X P4.0	100	156	500					
L605100R	5/8"---11WT	100	153						
L605150R		150	203						
L606100R	3/4"---10WT	100	153	800					
L606150R		150	203						

Heavy duty aluminum base leveling feet LR series

Application: Clean room equipment, aluminum extrusion equipment, high-load mechanical equipment

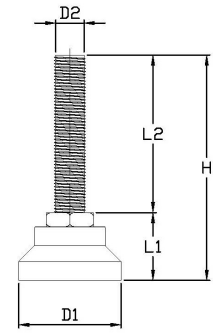
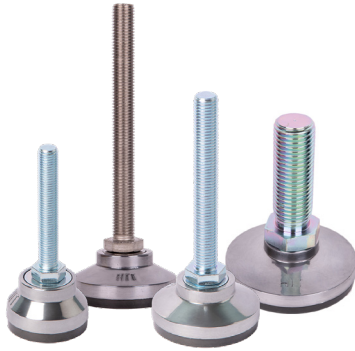

Unit: mm

Item No.	Bolt Material	Base Material	D1	L1	D2	L2	H	Load capacity (Kg)		
L9016080R	Zinc plated (SS41)	Aluminum alloy with rubber pad	90	51	M16 X P2.0	80	131	1000		
L9016100R						100	151			
L9016130R						130	181			
L9016150R						150	201			
L9016180R						180	231			
L9016200R						200	251			
L9016250R						250	301			
L9020080R					M20 X P2.5	80	131		1500	
L9020100R						100	151			
L9020130R						130	181			
L9020150R			150	201						
L9020180R			180	231						
L9020200R			200	251						
L9024100R			M24 X P3.0	100		156	1500			
L9024150R				150	206					
L9030100R				M30 X P3.5	100	156				
L9030150R					150	206				
L9036100R			M36 X P4.0	100	156					
L905100R			5/8" ---11WT	100	153	1000				
L905150R				150	203					
L906100R	3/4" ---10WT	100	152	1500						
L906150R		150	202							
L12020080R			120	51	M20 X P2.5	80		131	1500	
L12020100R						100	151			
L12020130R						130	181			
L12020150R						150	201			
L12020180R						180	231			
L12020200R						200	251			
L12024100R						M24 X P3.0	100	156		1500
L12024150R					150		206			
L12030100R					M30 X P3.5		100	156		
L12030150R							150	206		
L12036100R			M36 X P4.0	100	156					
L1206100R			3/4" ---10WT	100	152	1500				
L1206150R				150	202					

Heavy duty aluminum base leveling feet LS-R series

Application: Clean room equipment, aluminum extrusion equipment, high-load mechanical equipment

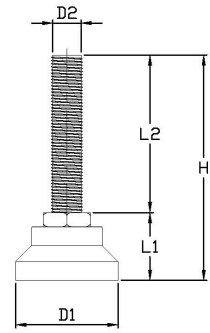
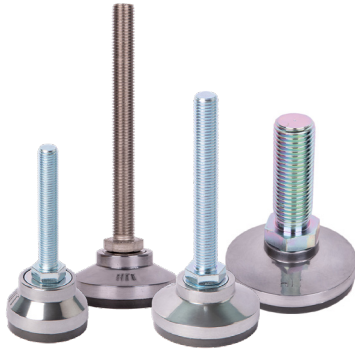

Unit: mm

Item No.	Bolt Material	Base Material	D1	L1	D2	L2	H	Load capacity (Kg)
LS6016080R	Stainless steel (SUS304)	Aluminum alloy with rubber pad	65	51	M16 X P2.0	80	131	500
LS6016100R						100	151	
LS6016130R						130	181	
LS6016150R						150	201	
LS6016180R						180	231	
LS6016200R						200	251	
LS6020080R						80	131	
LS6020100R				100	151			
LS6020130R				130	181			
LS6020150R				150	201			
LS6020180R				180	231			
LS6020200R				200	251			
LS6024100R				56	M24 X P3.0	100	156	
LS6024150R						150	206	
LS6030100R	M30 X P3.5	100	156					
LS6030150R		150	206					

Heavy duty aluminum base leveling feet LS-R series

Application: Clean room equipment, aluminum extrusion equipment, high-load mechanical equipment

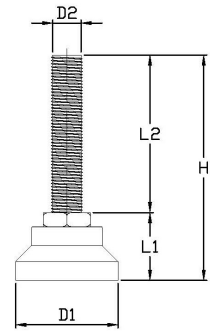
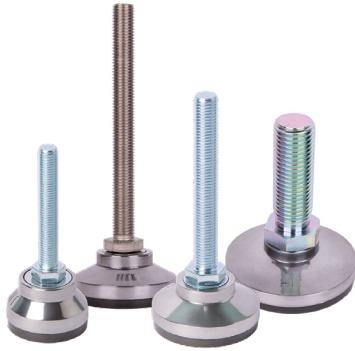

Unit: mm

Item No.	Bolt Material	Base Material	D1	L1	D2	L2	H	Load capacity (Kg)							
LS9016080R	Stainless steel (SUS304)	Aluminum alloy with rubber pad	90	51	M16 X P2.0	80	131	1000							
LS9016100R						100	151								
LS9016130R						130	181								
LS9016150R						150	201								
LS9016180R						180	231								
LS9016200R						200	251								
LS9020080R				56	M20 X P2.5	90	51	80	131	1500					
LS9020100R								100	151						
LS9020130R								130	181						
LS9020150R								150	201						
LS9020180R								180	231						
LS9020200R								200	251						
LS9024100R								56	M24 X P3.0		100	156	1500		
LS9024150R									150		206				
LS9030100R								56	M30 X P3.5		90	56	100	156	1500
LS9030150R													150	206	
LS12020080R	Stainless steel (SUS304)	Aluminum alloy with rubber pad	120	51	M20 X P2.5	80	131	1500							
LS12020100R						100	151								
LS12020130R						130	181								
LS12020150R						150	201								
LS12020180R						180	231								
LS12020200R						200	251								
LS12024100R				56	M24 X P3.0	100	156	1500							
LS12024150R					150	206									
LS12030100R				56	M30 X P3.5	120	56	100	156	1500					
LS12030150R								150	206						

Heavy duty stainless steel rotary leveling feet TCS series

Application: Clean room equipment, aluminum extrusion equipment, high-load mechanical equipment, Sloping ground

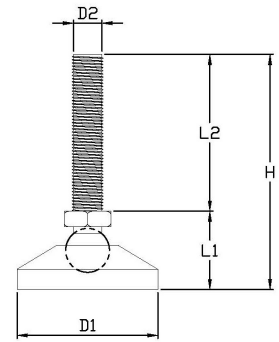

Unit: mm

Item No.	Bolt Material	Base Material	D1	L1	D2	L2	H	Load capacity (Kg)	
TCS7016080	Stainless steel (SUS304)	Stainless steel (SUS304)	70	50	M16 X P2.0	80	130	2000	
TCS7016100						100	150		
TCS7016150						150	200		
TCS7020100					M20 X P2.5	100	150		3000
TCS7020150						150	200		
TCS7016100R						Stainless steel (SUS304) with rubber pad	74		
TCS7016150R		150	204						
TCS7020100R		M20 X P2.5	100	154	3000				
TCS7020150R			150	204					

Heavy duty aluminum base leveling feet LC/LCS series

Application: Clean room equipment, aluminum extrusion equipment, high-load mechanical equipment, Sloping ground

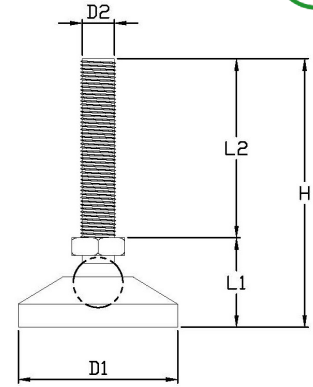

Unit: mm

Item No.	Bolt Material	Base Material	D1	L1	D2	L2	H	Load capacity (Kg)
LC7020100	Zinc plated (SS41)	Aluminum	70	42	M20 X P2.5	100	142	1500
LC7020150						150	192	
LCS7016100	M16 X P2.0				100	142	1000	
LCS7016150					150	192		
LCS7020100	M20 X P2.5				100	142	1500	
LCS7020150					150	192		
LCS10016100	Stainless steel (SUS304)		100		M16 X P2.0	100	142	1000
LCS10016150						150	192	
LCS10020100					M20 X P2.5	100	142	1500
LCS10020150						150	192	
LC7020100R	Zinc plated (SS41)	Aluminum alloy with rubber pad Electrical impedance $\leq 50K\Omega$	78	46	M20 X P2.5	100	146	1500
LC7020150R						150	196	
LCS7016100R	M16 X P2.0				100	146	1000	
LCS7016150R					150	196		
LCS7020100R	M20 X P2.5				100	146	1500	
LCS7020150R					150	196		

Heavy duty stainless steel leveling feet S series

Application: Clean room equipment, high-load mechanical equipment, Humid acid-base environment

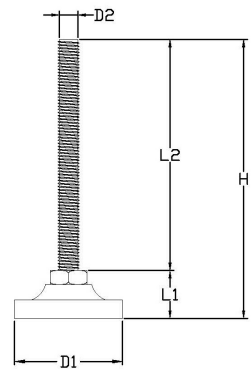

Unit: mm

Item No.	Bolt Material	Base Material	D1	L1	D2	L2	H	Load capacity (Kg)
S5016080	Stainless steel (SUS304)	Stainless steel (SUS304)	50	32	M16 X P2.0	80	112	2000
S5016100						100	132	
S5016130						130	162	
S5016150						150	182	
S5016180						180	212	
S5016200						200	232	
S5020080			M20 X P2.5		80	112	2500	
S5020100					100	132		
S5020130					130	162		
S5020150					150	182		
S5020180					180	212		
S5020200					200	232		
S7016080	Stainless steel (SUS304)	Stainless steel (SUS304)	70	32	M16 X P2.0	80	112	2000
S7016100						100	132	
S7016130						130	162	
S7016150						150	182	
S7016180						180	212	
S7016200						200	232	
S7020100			M20 X P2.5		100	132	2500	
S7020130					130	162		
S7020150					150	182		
S7020180					180	212		
S7020200					200	235		

Heavy duty stainless steel leveling feet S-R series

Application: Clean room equipment, high-load mechanical equipment, Humid acid-base environment

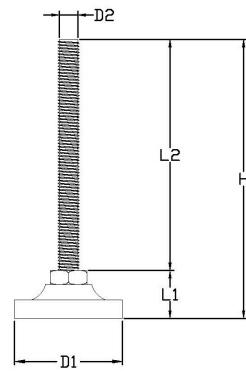

Unit: mm

Item No.	Bolt Material	Base Material	D1	L1	D2	L2	H	Load capacity (Kg)
S7016080R	Stainless steel (SUS304)	Stainless steel (SUS304) with rubber pad Electrical impedance $\leq 50K\Omega$	74	35	M16 X P2.0	80	115	2000
S7016100R						100	135	
S7016130R						130	165	
S7016150R						150	185	
S7016180R						180	215	
S7016200R						200	235	
S7020080R					M20 X P2.5	80	115	2500
S7020100R						100	135	
S7020130R						130	165	
S7020150R						150	185	
S7020180R	180	215						
S7020200R	200	235						

Nylon base rotary leveling feet C/CS series

Application: Sloping ground

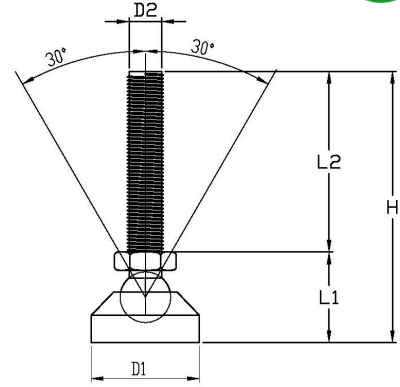

Unit: mm

Item No.	Bolt Material	Base Material	D1	L1	D2	L2	H	Load capacity (Kg)			
C6016100	Zinc plated (SS41)	Nylon	60	45	M16 X P2.0	100	145	500			
C6016150						150	195				
C9016100	100					47	M20 X P2.5		100	147	
C9016150									150	197	
C9020100T	Galvanized (SS41) one-piece molding		100	47	M20 X P2.5	100	147	800			
C9020150T						150	197				
CS6016100	Stainless steel (SUS304)		Nylon	60	45	M16 X P2.0	100	145	500		
CS6016150							150	195			
CS9016100	100						47	M16 X P2.0		100	147
CS9016150										150	197
CS6016100T	Stainless steel (SUS304) integrated molding	100		43	M16 X P2.0	100	143	500			
CS6016150T						150	193				
CS9016100T						45	100		145		
CS9016150T							150		195		
CS9020100T						47	M20 X P2.5		100	147	800
CS9020150T									150	197	

Heavy duty nylon base leveling feet D60 / DS60 series

Application: conveyor equipment , aluminum extrusion equipment, automation equipment

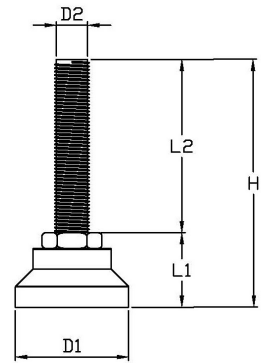

Unit: mm

Item No.	Bolt Material	Base Material	D1	L1	D2	L2	H	Load capacity (Kg)
D6016080	Zinc plated (SS41)	Nylon	65	43	M16 X P2.0	80	123	600
D6016100						100	143	
D6016130						130	173	
D6016150						150	193	
D6016180						180	223	
D6016200						200	243	
D6016250						250	293	
D6020080					M20 X P2.5	80	123	800
D6020100						100	143	
D6020130						130	173	
D6020150				150		193		
D6020180				180		223		
D6020200				200		243		
D6024100				M24 X P3.0		100	148	
D6024150					150	198		
D6030100					M30 X P3.5	100	148	
D6030150				150		198		
D6036100				M36 X P4.0	100	148	800	
D605100				5/8" – 11WT	100	146	600	
D605150					150	196		
D606100	3/4" – 10WT	100	144	800				
D606150		150	194					
DS6016080	Stainless steel (SUS304)	Nylon	65	43	M16 X P2.0	80	123	600
DS6016100						100	143	
DS6016130						130	173	
DS6016150						150	193	
DS6016180						180	223	
DS6016200						200	243	
DS6020080						M20 X P2.5	80	
DS6020100					100		143	
DS6020130					130		173	
DS6020150					150		193	
DS6020180				180	223			
DS6020200				200	243			
DS6024100				M24 X P3.0	100		148	800
DS6024150					150	198		
DS6030100					M30 X P3.5	100	148	
DS6030150				150		198		

Heavy duty nylon base leveling feet D90 / DS90 series

Application: conveyor equipment , aluminum extrusion equipment, automation equipment

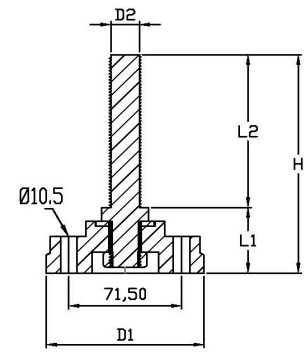

Unit: mm

Item No.	Bolt Material	Base Material	D1	L1	D2	L2	H	Load capacity (Kg)	
D9016080	Zinc plated (SS41)	Nylon	100	43	M16 X P2.0	80	123	600	
D9016100						100	143		
D9016130						130	173		
D9016150						150	193		
D9016180						180	223		
D9016200						200	243		
D9016250						250	293		
D9020080					M20 X P2.5	80	123	800	
D9020100						100	143		
D9020130						130	173		
D9020150				150		193			
D9020180				180		223			
D9020200				200	243				
D905100				5/8"—11WT	45	45	100	145	600
D905150							150	195	
D906100				3/4"—10WT	44	44	100	144	800
D906150							150	194	
D9024100				M24 X P3.0	48	48	100	148	800
D9024150							150	198	
D9030100							M30 X P3.5	100	
D9030150	150	198							
D9036100	M36 X P4.0	100	148						
DS9016080	Stainless steel (SUS304)	Nylon	100	43	M16 X P2.0	80	123	600	
DS9016100						100	143		
DS9016130						130	173		
DS9016150						150	193		
DS9016180						180	223		
DS9016200						200	243		
DS9020080						M20 X P2.5	80		123
DS9020100					100		143		
DS9020130					130		173		
DS9020150					150		193		
DS9020180				180	223				
DS9020200				200	243				
DS9024100				M24 X P3.0	48	48	100	148	800
DS9024150							150	198	
DS9030100				M30 X P3.5	48	48	100	148	
DS9030150							150	198	

Anti-vibration leveling feet R70/RS70 series

Application: Vibration machinery and equipment

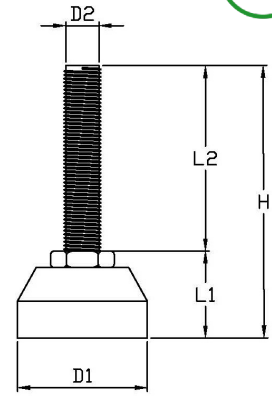

Unit: mm

Item No.	Bolt Material	Base Material	D1	L1	D2	L2	H	Load capacity (Kg)	
R7016080	Zinc plated (SS41)	Rubber	70	47	M16 X P2.0	80	127	800	
R7016100						100	147		
R7016130						130	177		
R7016150						150	197		
R7016180						180	227		
R7016200						200	247		
R7016250						250	297		
R7020080						M20 X P2.5	80		127
R7020100							100		147
R7020130							130		177
R7020150				150	197				
R7020180				180	227				
R7020200				200	247				
R7024100				48	M24 X P3.0		100		148
R7024150							150		198
R7030100							M30 X P3.5		100
R7030150				150	198				
R7036100				M36 X P4.0	100	148			
R705100				50	5/8" – 11WT	100	150		
R705150						150	200		
R706100	48	3/4" – 10WT	100	148					
R706150			150	198					
RS7016080	Stainless steel (SUS304)	Rubber	70	47	M16 X P2.0	80	127	800	
RS7016100						100	147		
RS7016130						130	177		
RS7016150						150	197		
RS7016180						180	227		
RS7016200						200	247		
RS7020080						M20 X P2.5	80		127
RS7020100							100		147
RS7020130							130		177
RS7020150							150		197
RS7020180				180	227				
RS7020200				200	247				
RS7024100				52	M24 X P3.0		100		147
RS7024150							150		197
RS7030100				M30 X P3.5	100		152		
RS7030150					150		202		

Anti-vibration leveling feet R90/RS90 series

Application: Vibration machinery and equipment

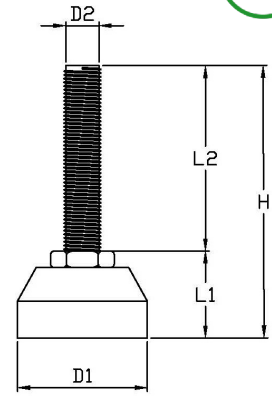

Unit: mm

Item No.	Bolt Material	Base Material	D1	L1	D2	L2	H	Load capacity (Kg)
R9016080	Zinc plated (SS41)	Rubber	90	46	M16 X P2.0	80	126	1000
R9016100						100	146	
R9016130						130	176	
R9016150						150	196	
R9016180						180	226	
R9016200						200	246	
R9016250					250	296		
R9020080					M20 X P2.5	80	126	
R9020100						100	146	
R9020130						130	176	
R9020150				150		196		
R9020180				180		226		
R9020200				200		246		
R905100				48	5/8"—11WT	100	148	
R905150				150	198			
R906100				50	3/4"—10WT	100	150	
R906150						150	200	
R9024100				51	M24 X P3.0	100	151	
R9024150						150	201	
R9030100						M30 X P3.5	100	
R9030150	150	201						
R9036100	M36 X P4.0	100	151					
RS9016080	Stainless steel (SUS304)	Rubber	90	46	M16 X P2.0	80	126	1000
RS9016100						100	146	
RS9016130						130	176	
RS9016150						150	196	
RS9016180						180	226	
RS9016200						200	246	
RS9020080					M20 X P2.5	80	126	
RS9020100						100	146	
RS9020130						130	176	
RS9020150						150	196	
RS9020180				180		226		
RS9020200				200		246		
RS9024100				51	M24 X P3.0	100	151	
RS9024150						150	201	
RS9030100						M30 X P3.5	100	
RS9030150				150	201			

Light duty anti-vibration leveling feet BN series

Application: conveyor equipment , aluminum extrusion equipment, automation equipment, slightly vibrating mechanical equipment

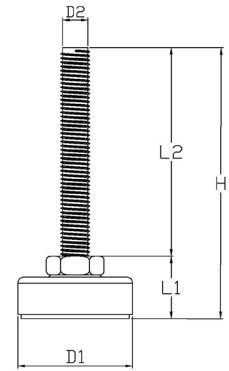

Unit: mm

Item No.	Bolt Material	Base Material	D1	L1	D2	L2	H	Load capacity (Kg)	
BN6012075	Zinc plated (SS41)	Zinc plated (SS41)	56	28	M12 X P1.75	75	103	300	
BN6012100						100	128		
BN6012150						150	178		
BN6016080				30	M16 X P2.0	80	110	500	
BN6016100						100	130		
BN6016130						130	160		
BN6016150						150	180		
BN6016180						180	210		
BN6016200						200	230		
BN6020080						M20 X P2.5	80		110
BN6020100							100		130
BN6020130							130		160
BN6020150							150		180
BN6020180				180	210				
BN6020200				200	230				
BN604075				28	1/2" – 12WT	75	103	300	
BN604100						100	128		
BN604150						150	178		
BN605075				30	5/8" – 11WT	75	105	500	
BN605100						100	130		
BN605150	150	180							

Light duty anti-vibration leveling feet BN series

Application: conveyor equipment , aluminum extrusion equipment, automation equipment, slightly vibrating mechanical equipment

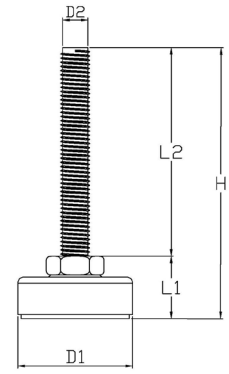

Unit: mm

Item No.	Bolt Material	Base Material	D1	L1	D2	L2	H	Load capacity (Kg)
BN8016080	Zinc plated (SS41)	Zinc plated (SS41)	74	34	M16 X P2.0	80	114	500
BN8016100						100	134	
BN8016130						130	164	
BN8016150						150	184	
BN8016180						180	214	
BN8016200						200	234	
BN8020080					M20 X P2.5	80	114	800
BN8020100						100	134	
BN8020130						130	164	
BN8020150						150	184	
BN8020180						180	214	
BN8020200						200	234	
BN805100	5/8" – 11WT	100	134	500				
BN805150		150	184					

Light duty anti-vibration leveling feet BT series

Application: conveyor equipment , aluminum extrusion equipment, automation equipment, slightly vibrating mechanical equipment

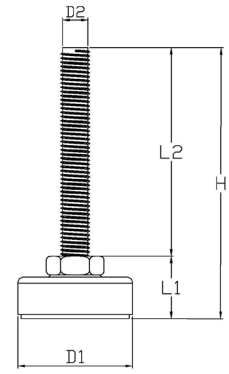

Unit: mm

Item No.	Bolt Material	Base Material	D1	L1	D2	L2	H	Load capacity (Kg)		
BT6012150NI	Bright Chrome	Bright Chrome	56	28	M12 X P1.75	150	178	300		
BT6016080NI						80	110			
BT6016100NI				100		130				
BT6016130NI				130		160				
BT6016150NI				150		180				
BT6016180NI				180		210				
BT6016200NI				200		230				
BT604075NI				28		1/2"–12WT	56	75	103	300
BT604100NI								100	128	

Light duty anti-vibration ED coating leveling feet B series

Application: conveyor equipment , aluminum extrusion equipment, automation equipment, slightly vibrating mechanical equipment

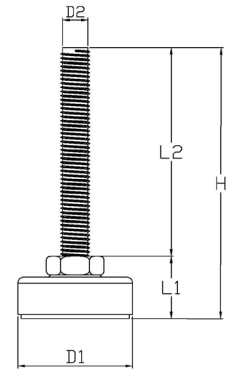

Unit: mm

Item No.	Bolt Material	Base Material	D1	L1	D2	L2	H	Load capacity (Kg)		
B403075	ED Coating (Black)	ED Coating (Black)	40	20	3/8"—16WT	75	95	300		
B408050					M8 X P1.25	50	70			
B408100						100	120			
B4010050				21	M10 X P1.5	50	71			
B4010100						100	121			
B4012050				22		50	72			
B4012100						100	122			
B4012150						150	172			
B6012050				27	M12 X P1.75	50	77		400	
B6012075						75	102			
B6012100			100			127				
B6012150			150			177				
B6016050			30			M16 X P2.0	50	80		500
B6016070							70	100		
B6016100				100	130					
B6016150			28	1/2"—12WT	150	180	400			
B604075					75	103				
B604100			29	5/8"—11WT	100	128	500			
B604150					150	178				
B605100			75		100	129	500			
B605150	150	179								
B8016100					33	M16 X P2.0		100	133	
B8016150	150	183								
B805100	32	5/8"—11WT	100	132	500					
B805150			150	182						

Light duty anti-vibration leveling feet BS series

Application: Clean room equipment, Stainless steel equipments, Humid environment, Vibration machinery and equipment

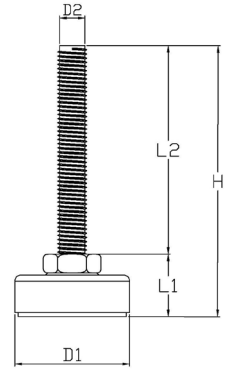

Unit: mm

Item No.	Bolt Material	Base Material	D1	L1	D2	L2	H	Load capacity (Kg)			
BS408050	Stainless steel (SUS304)	Stainless steel (SUS304) with rubber pad Electrical impedance <1000KΩ	40	20	M8 X P1.25	50	70	200			
BS4010050							50		72		
BS4010075							75		97		
BS4010100							22	M10 X P1.5	100	122	400
BS4012050								50	73		
BS4012075								75	98		
BS4012100								100	123		
BS4012150								150	173		
BS404050							23	M12 X P1.75	50	73	
BS404075								75	98		
BS404100					100	123					
					1/2" - 12WT	75	98				
						100	123				

Light duty anti-vibration leveling feet BS series

Application: Clean room equipment, Stainless steel equipments, Humid environment, Vibration machinery and equipment

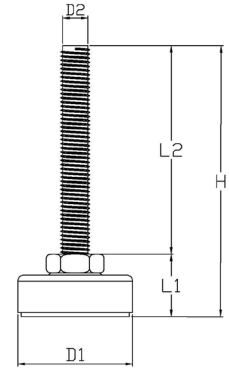

Unit: mm

Item No.	Bolt Material	Base Material	D1	L1	D2	L2	H	Load capacity (Kg)		
BS5512050	Stainless steel (SUS304)	Stainless steel (SUS304) with rubber pad Electrical impedance <1000KΩ	55	27	M12 X P1.75	50	77	400		
BS5512075						75	102			
BS5512100						100	127			
BS5512150						150	177			
BS5516050				30	M16 X P2.0	50	80	500		
BS5516075						75	105			
BS5516080						80	110			
BS5516100						100	130			
BS5516130						130	160			
BS5516150						150	180			
BS5516180			180	210						
BS5516200			200	230						
BS554050			27	1/2" – 12WT	55	50	77	400		
BS554075						75	102			
BS554100						100	127			
BS554150			150	177						
BS555100			29	5/8" – 11WT	55	100	129	500		
BS555150						150	179			
BS6012050			Stainless steel (SUS304)	Stainless steel (SUS304) with rubber pad Electrical impedance <1000KΩ	60	33	M12 X P1.75	50	83	400
BS6012075								75	108	
BS6012100	100	133								
BS6012150	150	183								
BS6016050	36	M16 X P2.0				50	86	500		
BS6016075						75	111			
BS6016080						80	116			
BS6016100						100	136			
BS6016130						130	166			
BS6016150						150	186			
BS6016180	180	216								
BS6016200	200	236								
BS604050	33	1/2" – 12WT			60	50	83	400		
BS604075						75	108			
BS604100						100	133			
BS604150	150	135								
BS605100	35	5/8" – 11WT			60	100	185	500		
BS605150						150	185			

Light duty leveling feet A series

Application: Mechanical equipment

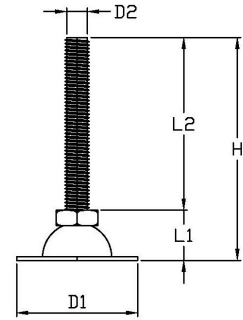

Unit: mm

Item No.	Bolt Material	Base Material	D1	L1	D2	L2	H	Load capacity (Kg)	
A324075	Zinc plated (SS41)	Zinc plated (SS41)	32	17	1/2"–12WT	75	92	200	
(angle type) A504075			50	20		75	95		
A6012075			60	23	M12 X P1.75	75	98		
A6012100						100	123		
A6012150						150	173		
A6016080						M16 X P2.0	80	103	300
A6016100							100	123	
A6016130							130	153	
A6016150			150	173					
A6016180			180	203					
A6016200			200	223					
A604075			1/2"–12WT	75	98	200			
A604100				100	123				
A604150				150	173				
A605075				5/8"–11WT	75		103	300	
A605100			100		128				
A605150			150		178				

Light duty leveling feet A series

Application: Mechanical equipment

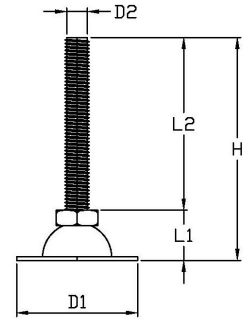

Unit: mm

Item No.	Bolt Material	Base Material	D1	L1	D2	L2	H	Load capacity (Kg)		
A7016080	Zinc plated (SS41)	Zinc plated (SS41)	70	29	M16 X P2.0	80	109	300		
A7016100						100	129			
A7016130						130	159			
A7016150						150	179			
A7016180						180	209			
A7016200						200	229			
A7020080						80	109			
A7020100					100	129				
A7020130					M20 X P2.5	130	159			
A7020150						150	179			
A7020180						180	209			
A7020200						200	229			
A704075						1/2"–12WT	75		101	200
A9016080					Zinc plated (SS41)	Zinc plated (SS41)	90		27	M16 X P2.0
A9016100			100	127						
A9016130			130	157						
A9016150			150	177						
A9016180	180	207								
A9016200	200	227								
A9020080	80	107								
A9020100	100	127								
A9020130	M20 X P2.5	130	157							
A9020150		150	177							
A9020180		180	207							
A9020200		200	227							
A905075		75	105							
A905100	5/8"–11WT	100	130							
A905150		150	180							

Light duty stainless steel leveling feet AS series

Application: Clean room equipment, humid environment

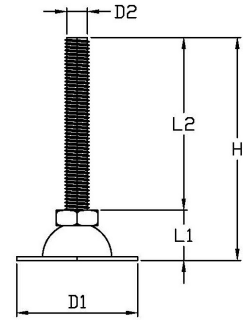

Unit: mm

Item No.	Bolt Material	Base Material	D1	L1	D2	L2	H	Load capacity (Kg)
AS5010050	Stainless steel (SUS304)	Stainless steel (SUS304)	50	18	M10 X P1.5	50	68	200
AS5010075						75	93	
AS5010100						100	118	
AS5012050				20	M12 X P1.75	50	70	300
AS5012075						75	95	
AS5012100						100	120	
AS504050			1/2"–12WT	50	70			
AS504075				75	95			
AS504100				100	120			

Light duty stainless steel leveling feet AS series

Application: Clean room equipment, humid environment

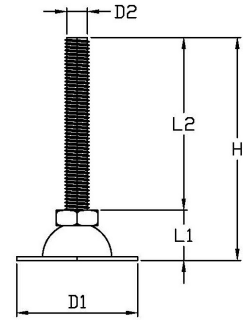

Unit: mm

Item No.	Bolt Material	Base Material	D1	L1	D2	L2	H	Load capacity (Kg)		
AS6012050	Stainless steel (SUS304)	Stainless steel (SUS304)	60	27	M12 X P1.75	50	77	300		
AS6012075						75	102			
AS6012100						100	127			
AS6012150						150	177			
AS6016050				29	M16 X P2.0	50	79	500		
AS6016075						75	104			
AS6016080						80	109			
AS6016100						100	129			
AS6016130						130	159			
AS6016150						150	179			
AS6016180			180	209						
AS6016200			200	229						
AS604050			27	1/2" – 12WT	70	50	77	300		
AS604075						75	102			
AS604100						100	127			
AS605100			32	5/8" – 11WT	70	100	132	500		
AS605150						150	182			
AS7012050			Stainless steel (SUS304)	Stainless steel (SUS304)	70	27	M12 X P1.75	50	77	300
AS7012075								75	102	
AS7012100								100	127	
AS7012150	150	177								
AS7016050	29	M16 X P2.0				50	79	500		
AS7016075						75	104			
AS7016080						80	109			
AS7016100						100	129			
AS7016130						130	159			
AS7016150						150	179			
AS7016180	180	209								
AS7016200	200	229								
AS704050	27	1/2" – 12WT			70	50	77	300		
AS704075						75	102			
AS704100						100	127			
AS705100	32	5/8" – 11WT			70	100	132	500		
AS705150						150	182			

Light duty anti-vibration leveling feet AS-R series

Application: Clean room equipment, humid environment

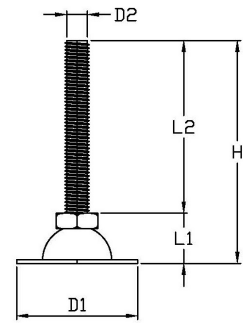

Unit: mm

Item No.	Bolt Material	Base Material	D1	L1	D2	L2	H	Load capacity (Kg)					
A7016080R	Zinc plated (SS41)	Zinc plated (SS41) with rubber pad	78	29	M16 X P2.0	80	113	300					
A7016100R						100	133						
A7016130R						130	163						
A7016150R						150	183						
A7016180R						180	213						
A7016200R						200	233						
A7020080R					M20 X P2.5	80	113						
A7020100R						100	133						
A7020130R						130	163						
A7020150R						150	183						
A7020180R						180	213						
A7020200R						200	233						
A704075R									26	1/2"–12WT	75	105	200
AS7012050R					Stainless steel (SUS304)	Stainless steel (SUS304) with rubber pad	78		31	M12 X P1.75	50	81	300
AS7012075R	75	106											
AS7012100R	100	131											
AS7012150R	150	181											
AS7016050R	M16 X P2.0	50	83	500									
AS7016075R		75	108										
AS7016080R		80	113										
AS7016100R		100	133										
AS7016130R		130	163										
AS7016150R		150	183										
AS7016180R	180	213											
AS7016200R	200	233											
AS704050R	31	1/2"–12WT	78	31				M12 X P1.75	50	81	300		
AS704075R									75	106			
AS704100R						100	131						
AS705100R	33	5/8"–11WT	78	33	M16 X P2.0	100	133	500					
AS705150R						150	183						

Light duty hole anchor leveling feet F/FS series

Application: conveyor equipment , cleanroom fence

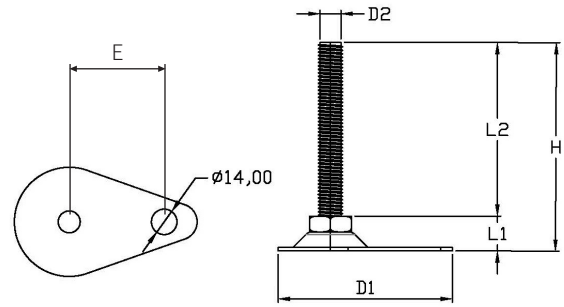

Unit: mm

Item No.	Bolt Material	Base Material	D1	L1	D2	L2	E	H	Load capacity (Kg)				
F6012075	Zinc plated (SS41)	Zinc plated (SS41)	100	21	M12 X P1.75	75	52	96	200				
F6012100						100		121					
F6012150						150		171					
F6016080				24	M16 X P2.0	100		80	104	300			
F6016100								100	124				
F6016130								130	154				
F6016150								150	174				
F6016180								180	204				
F6016200								200	224				
F604075				21	1/2"—12WT	100		75	96	200			
F604100								100	121				
F604150								150	171				
F605100								23	5/8"—11WT		100	123	300
F605150												150	
FS7012050				Stainless steel (SUS304)	Stainless steel (SUS304)	115		23	M12 X P1.75	50	69	73	200
FS7012075	75	98											
FS7012100	100	123											
FS7012150	150	173	300										
FS7016080	25	M16 X P2.0					100	80	105				
FS7016100								100	125				
FS7016130								130	155				
FS7016150								150	175				
FS7016180								180	205				
FS7016200			200					225					
FS704050	23	1/2"—12WT	100				50	73	200				
FS704075							75	98					
FS704100							100	123					
FS705100							25	5/8"—11WT		100		125	300
FS705150												150	

Light duty hole anchor leveling feet M/MS series

Application: conveyor equipment ,cleanroom fence

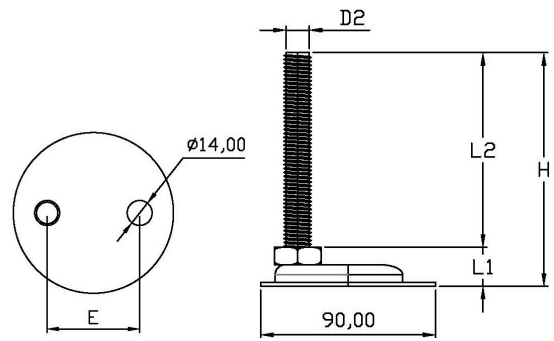

Unit: mm

Item No.	Bolt Material	Base Material	D1	L1	D2	L2	E	H	Load capacity (Kg)	
M9012075	Zinc plated (SS41)	Zinc plated (SS41)	90	21	M12 X P1.75	75	50	96	200	
M9012100						100		121		
M9012150						150		171		
M9016080				25	M16 X P2.0	25		80	105	300
M9016100								100	125	
M9016130								130	155	
M9016150								150	175	
M9016180								180	205	
M9016200								200	225	
M904100				21	1/2"–12WT	21		100	121	200
M904150								150	171	
M905100								100	126	
M905150	26	5/8"–11WT	26	150	176	300				
MS9012050	Stainless steel (SUS304)	Stainless steel (SUS304)	90	21	M12 X P1.75	50	50	71	200	
MS9012075						75		96		
MS9012100						100		121		
MS9012150				150	171					
MS9016080				25	M16 X P2.0	25		80	105	300
MS9016100								100	125	
MS9016130								130	155	
MS9016150								150	175	
MS9016180								180	205	
MS9016200								200	225	
MS904050				21	1/2"–12WT	21		50	71	200
MS904075								75	96	
MS904100	100	121								
MS905100	26	5/8"–11WT	26	100	126	300				
MS905150				150	176					

Light duty non-slip leveling feet G series

Application: display racks, furniture, light duty machinery and equipments

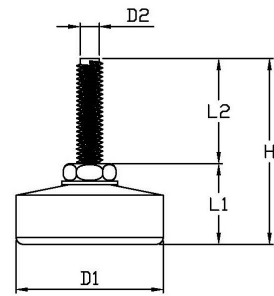

Unit: mm

Item No.	Bolt Material	Base Material	D1	L1	D2	L2	H	Load capacity (Kg)
G290625	Zinc plated (SS41)	Stainless steel (SUS304) Nylon	29	10	M6 X P1.0	25	35	50
G350625			35	16			30	
G3508030				21	M8 X P1.25	51		
G4208030			42	23			M10 X P1.5	
G4210050					3/8" - 16WT	73		
G423050							50	
G5010050								
G291050	ED Coating (Black)	ED Coating (Black)	29	16	M10 X P1.5	50	66	100
G291080						80	96	

Floor lock series

※Applicable to 4-8 inch casters

Application : High-altitude lift platform

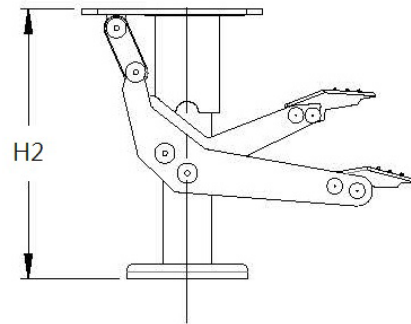
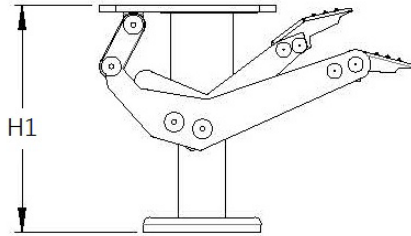
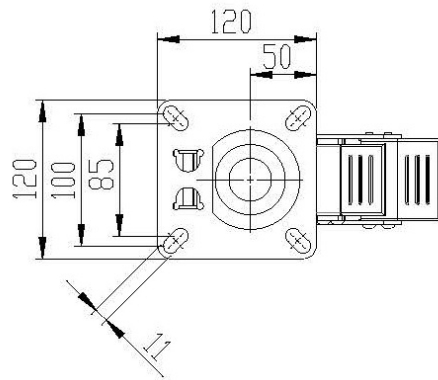

Unit: mm

Item No.	Material	Applicable caster size	H1	H2	Weight(Kg)	Load capacity (Kg)
SH004	Bright Chrome	100	125	150	1.6	200
SH005		125	154	180	1.7	
SH006		150	170	210	1.8	300
SH008		200	215	255	2	